

# DISPENSE-RITE® BFL SERIES PERFECT-FIT® CUP DISPENSER INSTALLATION INSTRUCTIONS

If an extra spring was included in the box, you must first decide which spring to use for your mounting application. If no extra spring was provided then proceed to STEP ONE.

To dispense paper or plastic cups in a horizontal position or foam cups in any position use the spring provided inside the cup dispenser -- proceed to STEP ONE.

To dispense paper or plastic cups in a vertical or angled position, remove the dispenser's end cap and replace the spring with the extra spring packaged separately inside the box (marked with an orange label) -- proceed to STEP ONE.

## STEP ONE - BAFFLE SELECTION & INSTALLATION

- Remove the mounting collar from the cup dispenser. To remove, rotate mounting collar clockwise and slide it off the rear of the dispensing tube.
- If the dispenser was shipped with a single rubber baffle pre-installed, no changes are required -- proceed to STEP TWO (see reverse side).
- If the dispenser was packaged with a set of rubber baffles, you must determine which is the correct baffle for your particular cup size. Refer to the diagrams shown on the right for correct baffle sizing.
- Remove the four thumbscrews on the underside of the ring bezel and remove the ring bezel from the unit. Remove cardboard insert and discard.
- Install the correct rubber baffle onto the ring bezel.
- Re-install the ring bezel by lining up the four posts with the holes in the stainless steel washer. Replace the four thumbscrews and hand-tighten until secure.
- Insert a full sleeve of cups into the dispenser to test if the baffle is the proper size for your cups. If you are not satisfied with the dispensing action a baffle change may be required.
- When you are satisfied with the dispensing action, the dispenser is ready for counter installation -- proceed to STEP TWO (see reverse side).

Questions? Call (847) 753-9595, ext. 25 8:00 AM - 5:00 PM CST



Diversified Metal Products, Inc.

2205 Carlson Drive • Northbrook, IL 60062 • (847) 753-9595 • fax (847) 753-9648  
www.dispense-rite.com • sales@dispense-rite.com

### BFL-2 Series Rubber Baffles (select one)

1 Notch for Small Baffle

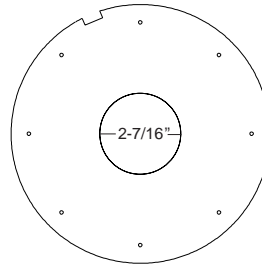

**Small Baffle (1 notch)**

Cup Rim Diameters: 3" - 3 1/4"  
Approx. Cup Sizes: 8 - 14 oz.  
Part: XRB-2SM

2 Notches for Medium Baffle

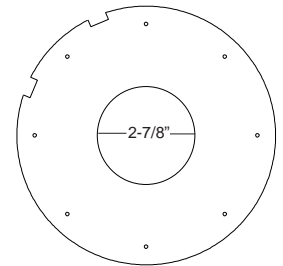

**Medium Baffle (2 notches)**

Cup Rim Diameters: 3 3/8" - 3 3/4"  
Approx. Cup Sizes: 16 - 24 oz.  
Part: XRB-2MD

3 Notches for Large Baffle

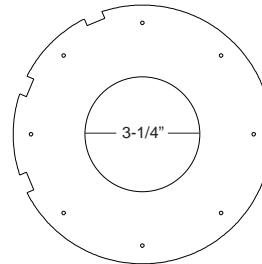

**Large Baffle (3 notches)**

Cup Rim Diameters: 3 3/4" - 4 1/4"  
Approx. Cup Sizes: 24 - 32 oz.  
Part: XRB-2LG

4 Notches for Extra Large Baffle

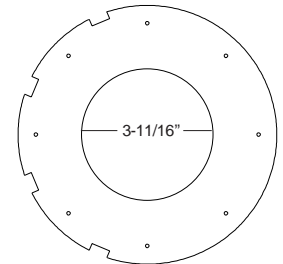

**Extra Large Baffle (4 notches)**

Cup Rim Diameters: 4 1/4" - 4 1/2"  
Approx. Cup Sizes: 32 - 44 oz.  
Part: XRB-2XL

### BFL-3 Series Rubber Baffles (select one)

1 Notch for Extra Large Baffle

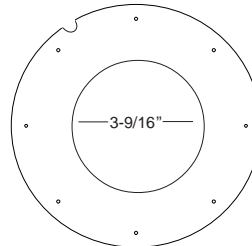

**Extra Large Baffle (1 notches)**

Cup Rim Diameters: 4 1/2" - 4 5/8"  
Approx. Cup Size: 44 oz.  
Part: XRB-3XL

2 Notches for Extra Large 2 Baffle

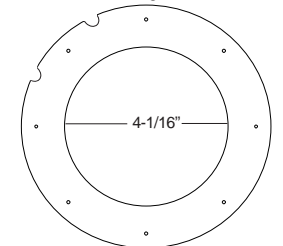

**Extra Large 2 Baffle (2 notches)**

Cup Rim Diameters: 4 3/4" - 5"  
Approx. Cup Size: 44 - 64 oz.  
Part: XRB-3XL-2

No Notches for Jumbo Baffle

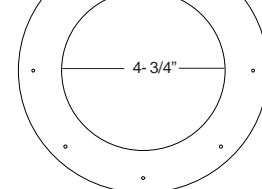

**Jumbo Baffle (no notches)**

Cup Rim Diameters: 5 1/8" - 5 1/4"  
Approx. Cup Size: 64 oz.  
Part: XRB-3JM

# STEP TWO - DISPENSER INSTALLATION

When installed, the cup dispenser is fully supported by the mounting collar. No additional bracing is required in any mounting position -- horizontal, vertical or angled.

- Cut the proper size hole for your cup dispenser. (Use the dimension in row "C" from the chart below)
- Insert the mounting collar in the hole, aligning the "UP" arrow to the top in a horizontal or angled application and to the rear in a vertical mounting application.
- Drill four 1/8" (3mm) holes and fasten the mounting collar with the screws provided with the unit.
- Insert the cup dispenser into the mounting collar so that the clip is aligned with the "UP" arrow. (See Fig. 1 & 2)
- Slide the dispenser in until the ring bezel is completely flush with the mounting surface.
- Support the dispenser with your hand inside the tube and rotate the ring bezel counterclockwise approximately 150° to secure the dispenser inside the mounting collar.
- To remove for cleaning or baffle replacement, rotate the dispenser clockwise 150° and pull straight out.

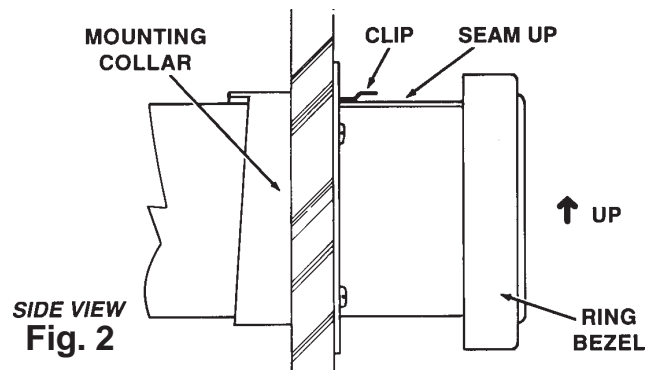
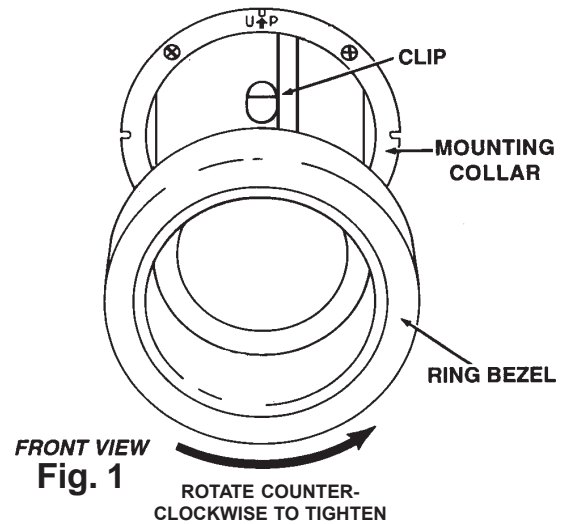

| Reference                          | <small>ONE-SIZE-FITS-ALL</small><br>BFL-2 | <small>ONE-SIZE-FITS-ALL</small><br>BFL-2S | <small>ONE-SIZE-FITS-ALL</small><br>BFL-2F | BFL-2F-SM                | BFL-2F-MD                    | BFL-2F-LG                     | BFL-2F-XL                      | BFL-3                          |
|------------------------------------|---|--|--|--------------------------|------------------------------|-------------------------------|--------------------------------|--------------------------------|
| <b>Cup Rim Diameter Range</b>      | 3" - 4 1/2"<br>77 - 114mm                 | 3" - 4 1/2"<br>77 - 114mm                  | 3" - 4 1/2"<br>77 - 114mm                  | 3" - 3 1/4"<br>77 - 83mm | 3 3/8" - 3 3/4"<br>86 - 95mm | 3 3/4" - 4 1/4"<br>95 - 108mm | 4 1/4" - 4 1/2"<br>108 - 114mm | 4 1/2" - 5 1/4"<br>114 - 133mm |
| <b>A Under Counter Length</b>      | 22"<br>559mm                              | 19"<br>483mm                               | 22"<br>559mm                               | 22"<br>559mm             | 22"<br>559mm                 | 22"<br>559mm                  | 22"<br>559mm                   | 22"<br>559mm                   |
| <b>B Ring Bezel Diameter</b>       | 6 7/8"<br>175mm                           | 6 7/8"<br>175mm                            | 6 7/8"<br>175mm                            | 6 7/8"<br>175mm          | 6 7/8"<br>175mm              | 6 7/8"<br>175mm               | 6 7/8"<br>175mm                | 7 3/8"<br>187mm                |
| <b>C Mounting Collar Cut Out</b>   | 5 1/4"<br>134mm                           | 5 1/4"<br>134mm                            | 5 1/4"<br>134mm                            | 5 1/4"<br>134mm          | 5 1/4"<br>134mm              | 5 1/4"<br>134mm               | 5 1/4"<br>134mm                | 5 3/4"<br>146mm                |
| <b>D Rubber Baffle(s) Included</b> | SM, MD, LG & XL                           | SM, MD, LG & XL                            | SM, MD, LG & XL                            | SMALL                    | MEDIUM                       | LARGE                         | EXTRA LARGE                    | XL, XL-2 & JUMBO               |
| <b>E Spring(s) Included</b>        | "F" & "P" Springs                         | "F" & "P" Springs                          | "F" Spring                                 | "F" Spring               | "F" Spring                   | "F" Spring                    | "F" Spring                     | "F" & "P" Springs              |
| <b>NSF Listed</b>                  | <b>NSF</b>                                | <b>NSF</b>                                 | <b>NSF</b>                                 | <b>NSF</b>               | <b>NSF</b>                   | <b>NSF</b>                    | <b>NSF</b>                     | <b>NSF</b>                     |

"F" Spring (Light Spring): Foam cups in any position. Paper or plastic cups in a horizontal position.

"P" Spring (Heavy Spring): Paper or plastic cups in a vertical or angled position.



**Diversified Metal Products, Inc.**

2205 Carlson Drive • Northbrook, IL 60062 • (847) 753-9595 • fax (847) 753-9648  
www.dispense-rite.com • sales@dispense-rite.com