

DISPENSE-RITE® SLR-STRAW-2 INSTALLATION & OPERATION INSTRUCTIONS

The straw dispenser is shipped completely assembled but it will require in-counter installation prior to initial usage.

Important note: This product is shipped configured for use with standard length drinking straws (approximately 8.5" L). If you are using a jumbo length straw you may need to reverse the orientation of the plunger inside the dispenser to accommodate longer straws. See SECTION TWO - JUMBO LENGTH STRAWS for details.

SECTION ONE - STRAW DISPENSER INSTALLATION

- 1** Cut a 5-1/4" diameter hole into the mounting surface.

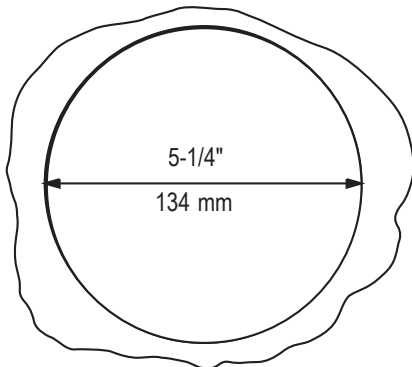

- 2** Turn the cover ring counterclockwise to remove from dispenser.

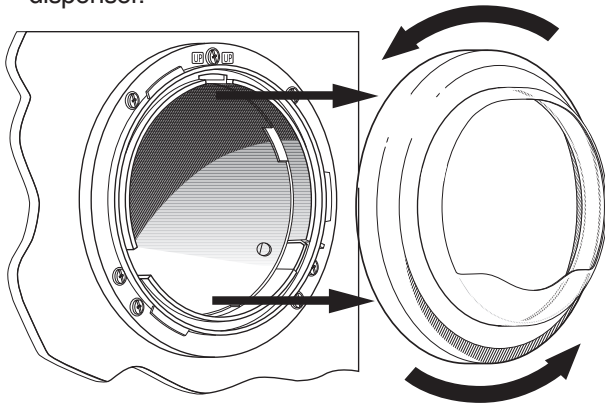

- 3** Insert the dispenser into the mounting hole. Push dispenser all the way in until it is flush with the counter and align the "UP" mark to the top.

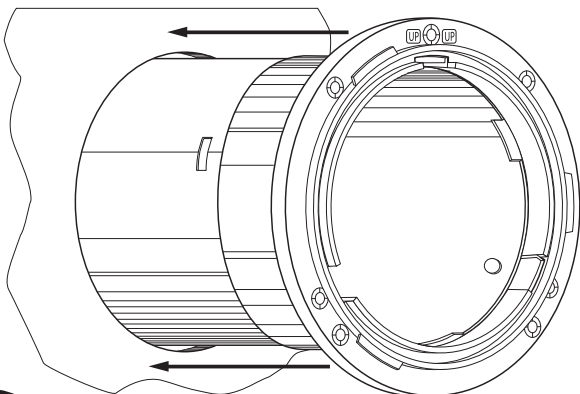

- 4** Drill four 9/64" pilot holes in the locations shown below. Fasten the dispenser with the four #10 screws provided.

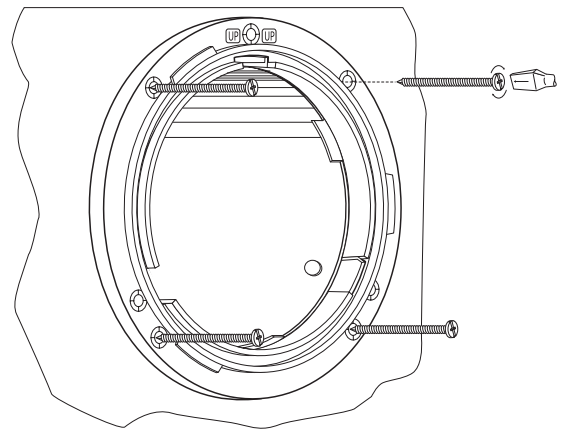

- 5** Place cover ring on the mounting head and rotate clockwise to secure.

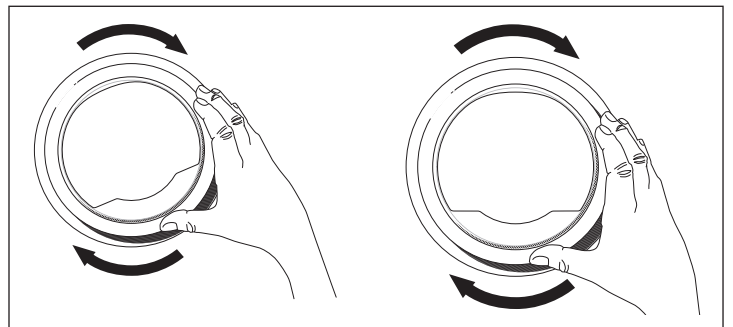
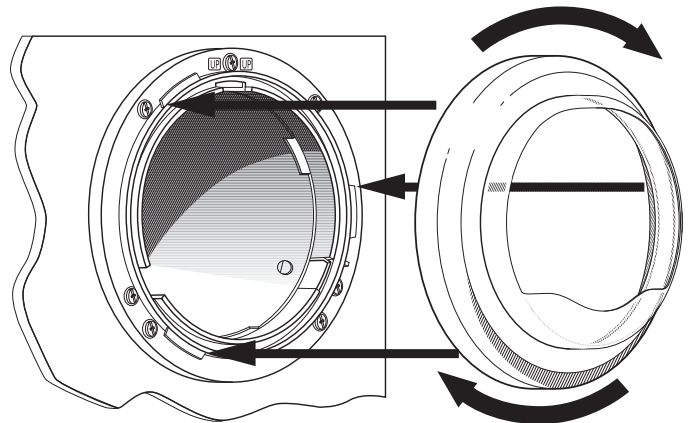

Diversified Metal Products, Inc.

2205 Carlson Drive • Northbrook, IL 60062 • (847) 753-9595 • fax (847) 753-9648
www.dispense-rite.com • sales@dispense-rite.com

SECTION TWO - LOADING AND OPERATION

- 1** To load the straws they may inserted directly into the opening on the faceplate.

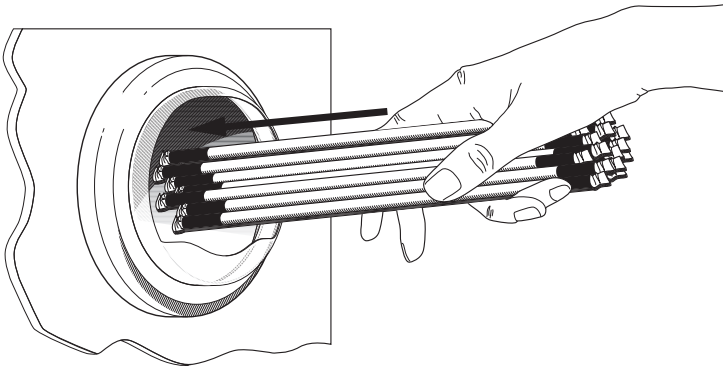

- 2** To remove straws grasp with your thumb and index finger and pull straight out.

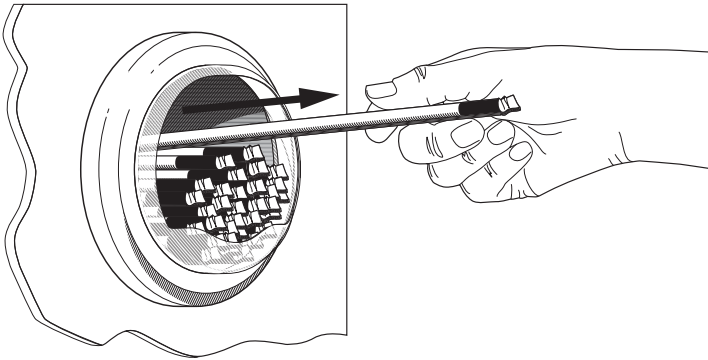

JUMBO LENGTH STRAWS

This product is shipped configured for use with standard length drinking straws (approximately 8.5" L).

If you are using a jumbo length straw you may need to reverse the orientation of the plunger inside the dispenser to accommodate longer straws.

- 1** To reverse the plunger the cover ring must be removed. Turn the cover ring counterclockwise to remove from dispenser.

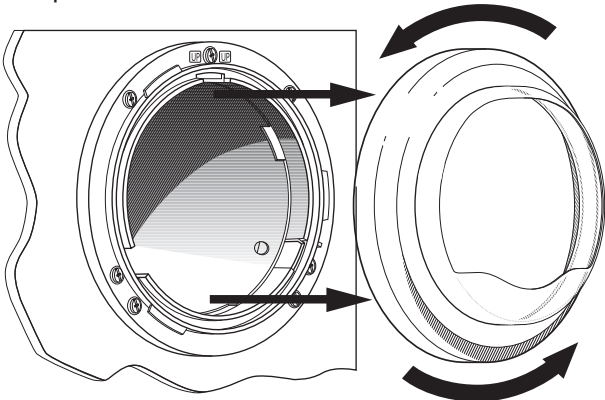

- 2** Once the cover ring has been removed take the plunger out of the front of the unit and reverse its orientation. It may now be reinserted into the dispenser for use with jumbo length straws.

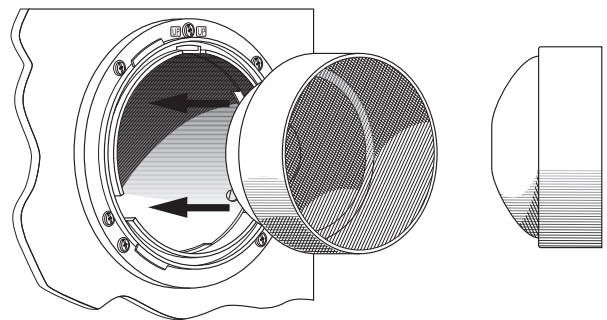
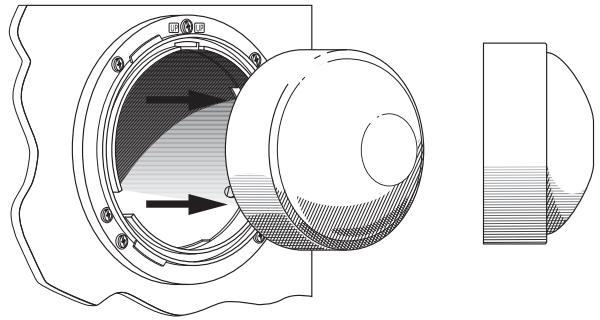

- 3** Place straw dispenser cover ring on the mounting head and rotate clockwise to secure.

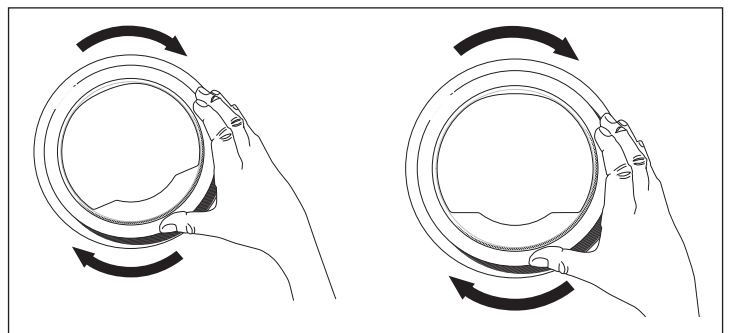
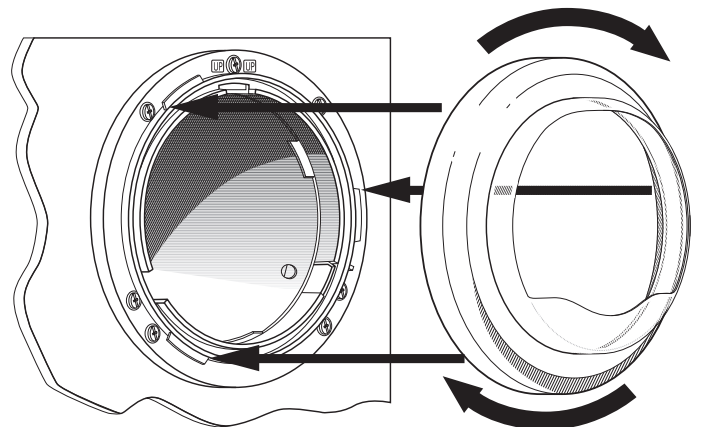

Diversified Metal Products, Inc.

2205 Carlson Drive • Northbrook, IL 60062 • (847) 753-9595 • fax (847) 753-9648
www.dispense-rite.com • sales@dispense-rite.com