

INSTALLATION INSTRUCTIONS FOR *DISPENSE-RITE*® 705-DS SIDE MOUNT CONE DISPENSER

The 705-DS side mount ice cream cone dispenser is designed to accommodate a variety of sizes of flat bottom cake cones. This dispenser is completely assembled but may require a minor modification to the rubber baffles. Please refer to the instructions below for the recommended mounting procedure and possible baffle modification.

1. Determine which side of the ice cream freezer the cone dispenser will be mounted. Make sure that access to the rear door is not restricted if this unit is intended for a rear loading application. Please verify that the location of the cone dispenser will not interfere with any operational part of the the freezer equipment.
2. Install the two “L” clips on the proper side of the cone dispenser using the machine screws provided. Place door hinges to the top and the baffle plate to the front.
3. Hold dispenser to the side of the freezer and position relative to top and front of the freezer. Rotate unit so that the front of the dispenser is vertical and set back from the front of the freezer as desired. (see Figure 1)
4. Mark the location of the keyhole for the front “L” clip on the freezer side. Place the bracket with a screw and two slots over the keyhole location and drill two 1/8” diameter holes in the center of the slots. It may be necessary to center punch the location prior to drilling. Mount the front bracket with the two #10 sheet metal screws provided. (see Figure 2)
5. Hang the cone dispenser on the front bracket and attach the rear bracket to the rear “L” clip. Rotate the cone dispenser to the proper orientation and mark the two slot locations. Drill two 1/8” diameter holes in the center of the slots and attach the rear bracket with the two #10 sheet metal screws provided. (See Figure 2)
6. Load cones in the rear of the dispenser by lifting the rear door. Do not load cones through the front door. If rear loading cannot be accommodated it will be necessary to remove the dispenser from the brackets, load cones and reattach the unit.
7. If cones break as they are being dispensed, carefully cut back the slits in the rubber baffles to the proper location as required. **Important Note: Do not overcut rubber baffles as it will result in improper dispensing.** Rubber baffles provided with this unit will handle all sizes of cones up through #35 without any modifications.

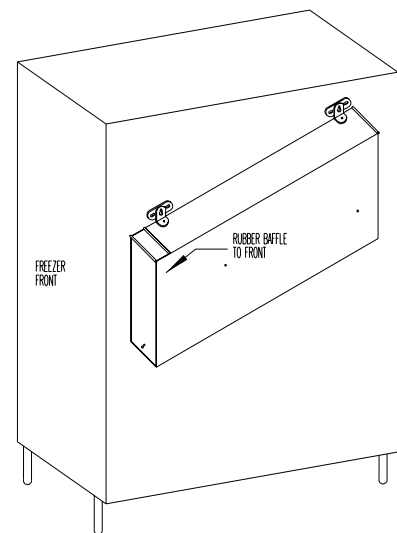

Figure 1

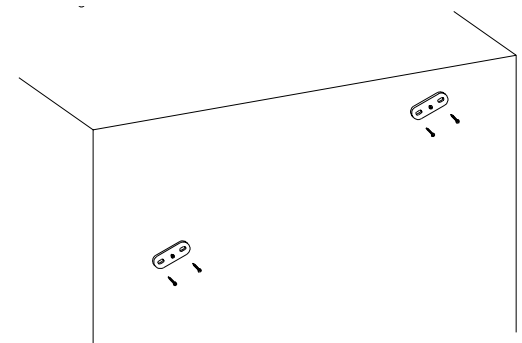

Figure 2

DISPENSE-RITE®

Diversified Metal Products, Inc.

2205 Carlson Drive • Northbrook, IL 60062 • (847) 753-9595 • fax (847) 753-9648
www.dispense-rite.com • sales@dispense-rite.com