

ADJ-1, ADJ-1.50, ADJ-2 & ADJ-3 SERIES ADJUSTMENT & INSTALLATION INSTRUCTIONS

The cup dispenser is completely assembled but will require a minor adjustment before it can be installed. A small flat head screwdriver and a full sleeve of cups are required for this procedure.

If an extra spring was included in the box, you must first decide which spring to use for your application.

To dispense paper or plastic cups in a horizontal mounting position or foam cups in any mounting position use the spring pre-installed inside the cup dispenser -- proceed to STEP ONE.

To dispense paper or plastic cups in a vertical or angled mounting position, remove the dispenser's end cap and replace the spring with the spring packaged separately with the dispenser (marked with orange label) -- proceed to STEP ONE.

STEP ONE - ADJUSTMENT

DO NOT BEND ADJUSTMENT CLIPS

- Remove the mounting collar from the cup dispenser.
- Loosen adjustment screw(s). Turn ring bezel counterclockwise to open the cup dispenser to its widest adjustment position. (See Figures 1 & 2)
- Insert a stack of approximately 12 cups, rim first, so that the rim of the top cup is located slightly below the top portion of the adjustment clips. (See Figure 1)
- Rotate the ring bezel clockwise until the adjustment clips are slightly tighter than the cup's rim. **While adjusting the dispenser it is very important to hold the dispenser in the same position as it will be installed (horizontal, vertical or angled). This will ensure that the spring tension is the same while you adjust the dispenser as it will be when it is installed.**
- Push the entire stack of cups below the level of the adjustment screw(s), being careful not to turn the ring bezel. Tighten the screw(s) firmly and fill the dispenser with three quarters of a sleeve of cups.
- Check the dispensing action. If more than one cup comes out, loosen the adjustment screw(s) and rotate the ring bezel slightly clockwise. If the cups are difficult to remove or the rims are damaged, loosen the adjustment screw(s) and rotate the ring bezel slightly counterclockwise. Retighten the adjustment screw(s). (See Figure 2)
- When you are satisfied with the dispensing action, the dispenser is ready for installation -- proceed to STEP TWO (See reverse side).

Questions? Call (847) 753-9595, ext. 25 8:00 AM - 5:00 PM CST

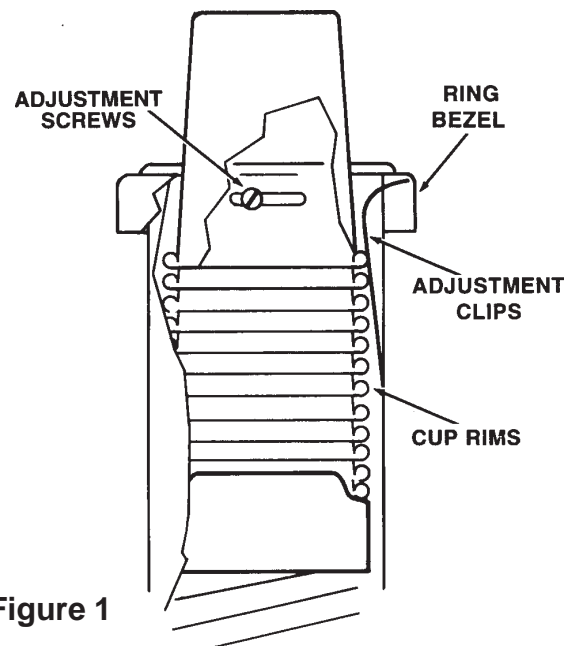

Figure 1

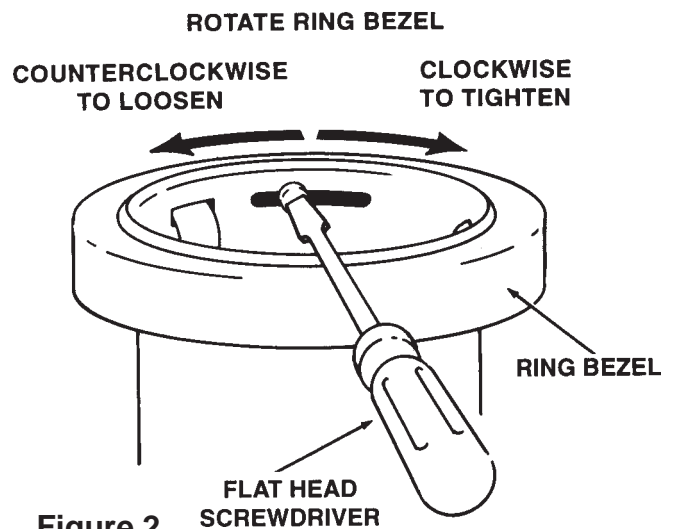

Figure 2



DISPENSE-RITE®

Diversified Metal Products, Inc.

2205 Carlson Drive • Northbrook, IL 60062 • (847) 753-9595 • fax (847) 753-9648
www.dispense-rite.com • sales@dispense-rite.com

STEP TWO - DISPENSER INSTALLATION

When installed, the cup dispenser is fully supported by the mounting collar. No additional bracing is required in any mounting position -- horizontal, vertical or angled.

- Cut the proper size hole for your cup dispenser. (Use the dimension in row "D" from the chart below)
- Insert the mounting collar in the hole, aligning the "UP" arrow to the top in a horizontal or angled application and to the rear in a vertical mounting application.
- Drill four 1/8" (3mm) holes and fasten the mounting collar with the screws provided with the unit.
- Insert the cup dispenser into the mounting collar so that the clip is aligned with the "UP" arrow. (See Figures 3 & 4)
- Slide the dispenser in until the ring bezel is completely flush with the mounting surface.
- Support the dispenser with your hand inside the tube and rotate the ring bezel counterclockwise approximately 150° to secure the dispenser inside the mounting collar.
- To remove for cleaning or adjustment, rotate the dispenser clockwise approximately 150° and pull straight out.

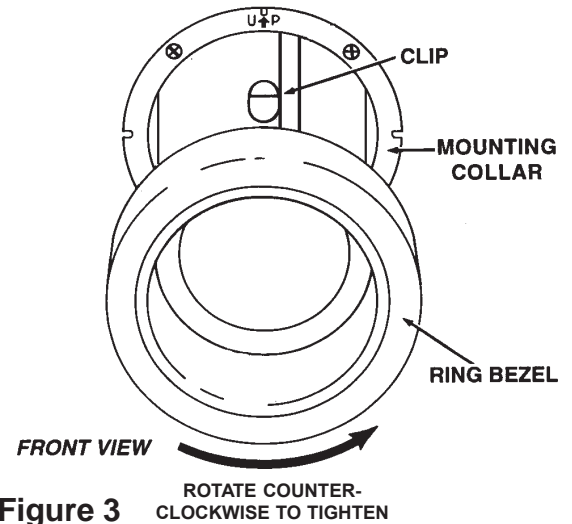

Figure 3 ROTATE COUNTER-CLOCKWISE TO TIGHTEN

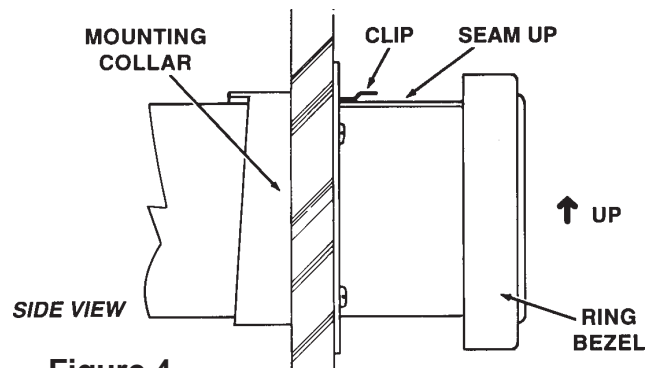

Figure 4

| Reference | ONE-SIZE-FITS-ALL | | ONE-SIZE-FITS-ALL | | ADJ-3 |
|----------------------------------|------------------------------|--------------------------|---------------------------|---------------------------|--------------------------------|
| | ADJ-1 | ADJ-1.50 | ADJ-2 | ADJ-2S | |
| Cup Rim Diameter Range | 2 1/2" - 3 1/2" 64 - 89mm | 3" - 3 7/8" 77 - 98mm | 3" - 4 5/8" 77 - 118mm | 3" - 4 5/8" 77 - 118mm | 4 1/2" - 5 1/4" 114 - 133mm |
| A Under Counter Length | 22" 559mm | 22" 559mm | 22" 559mm | 19" 483mm | 22" 559mm |
| B Ring Bezel Diameter | 5 3/8" 137mm | 5 5/8" 143mm | 6 7/8" 175mm | 6 7/8" 175mm | 7 3/8" 187mm |
| C Tube Diameter | 3 11/16" 94mm | 4 1/16" 103mm | 4 7/8" 124mm | 4 7/8" 124mm | 5 1/2" 140mm |
| D Mounting Collar Cut Out | 4" 102mm | 4 1/2" 114mm | 5 1/4" 134mm | 5 1/4" 134mm | 5 3/4" 146mm |
| | NSF | NSF | NSF | NSF | NSF |

"F" Spring (Light Spring): Foam cups in any position. Paper or plastic cups in a horizontal position.

"P" Spring (Heavy Spring): Paper or plastic cups in a vertical or angled position.



DISPENSE-RITE®

Diversified Metal Products, Inc.

2205 Carlson Drive • Northbrook, IL 60062 • (847) 753-9595 • fax (847) 753-9648

www.dispense-rite.com • sales@dispense-rite.com