

DISPENSE-RITE® BFL SERIES PERFECT-FIT® CUP DISPENSING CABINET SETUP INSTRUCTIONS

BFL Series Cup Dispensing Cabinets feature **DISPENSE-RITE** interchangeable baffle cup dispensers which accommodate paper, plastic or foam cups and containers. The dispenser is completely assembled, however it will require that the proper size baffle be installed before it can be used. You will need sample cups in order to select the correct baffle size for the dispenser.

STEP ONE - REMOVING THE DISPENSER

Before the correct baffle can be installed the dispenser must first be removed from the cabinet. Turn the outside of the ring bezel clockwise and remove the dispenser from the front of the cabinet. **If this is the first time the dispenser has been taken out of the cabinet please remove and discard the black plastic shipping spacer that has been taped onto the rear of the dispenser.** You are now ready to select and install the correct baffle for use with your particular cup size.

STEP TWO - BAFFLE SELECTION & INSTALLATION

- If the dispenser was shipped with a single rubber baffle pre-installed, no changes are required -- proceed to STEP THREE.
- If the dispenser was packaged with a set of rubber baffles, you must determine which is the correct baffle for your particular cup size. The rubber baffles can be found inside the dispenser behind the cardboard insert. Refer to the diagrams shown on the right for correct baffle sizing. (See Figure 1)
- Remove the four thumbscrews on the underside of the ring bezel and remove the ring bezel from the unit. Remove cardboard insert and discard. Remove rubber baffle kit from inside the dispenser.
- Install the correct rubber baffle onto the ring bezel.
- Re-install the ring bezel by lining up the four posts with the holes in the stainless steel washer. Replace the four thumbscrews and hand-tighten until secure.
- Insert a full sleeve of cups into the dispenser to test if the baffle is the proper size for your cups. If you are not satisfied with the dispensing action a baffle change may be required.
- When you are satisfied with the dispensing action, the dispenser is ready for installation -- proceed to STEP THREE.

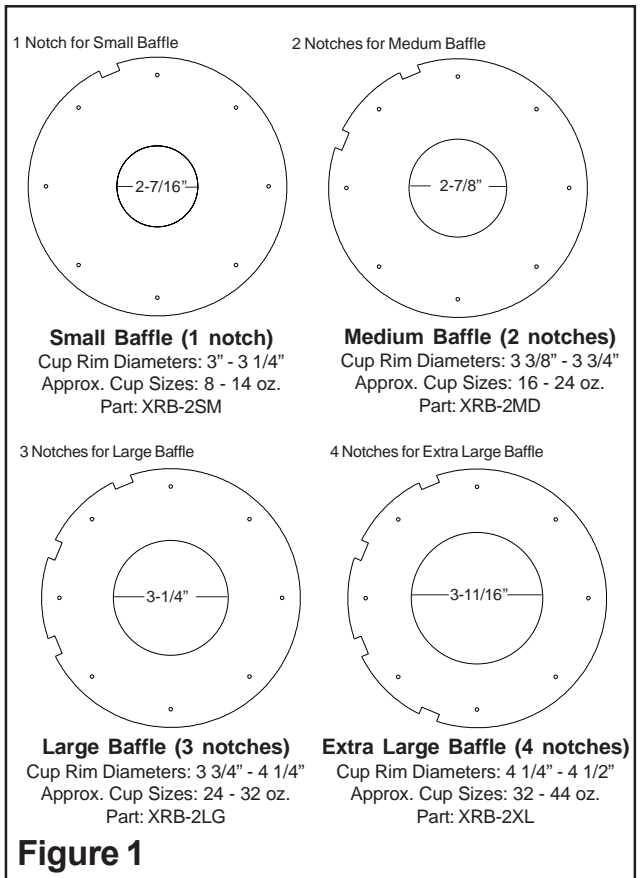

Figure 1

STEP THREE - REINSTALLING THE DISPENSER

- Remove all cups from the dispenser. Insert the cup dispenser into the mounting collar so that the clip is aligned with the "UP" arrow. (See Figure 2)
- Slide the dispenser in until the ring bezel is completely flush with the mounting surface.
- Support the dispenser with your hand inside the tube and rotate the ring bezel counterclockwise approximately 150° to secure the dispenser inside the mounting collar.
- To remove for cleaning or baffle replacement, rotate the dispenser clockwise 150° and pull straight out.

Questions? Call (847) 753-9595, ext. 25 8:00 AM - 5:00 PM ST

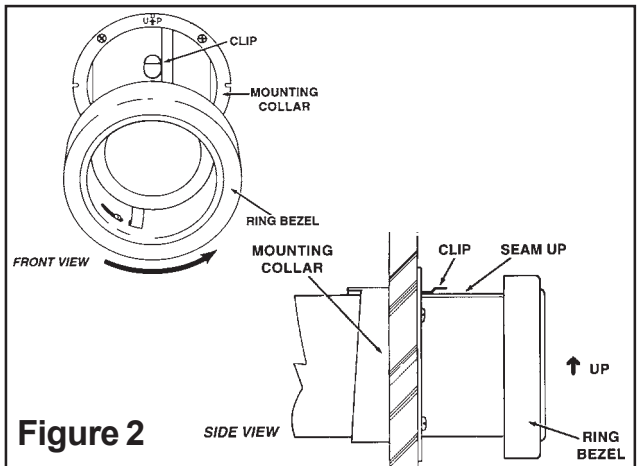

Figure 2



Diversified Metal Products, Inc.

2205 Carlson Drive • Northbrook, IL 60062 • (847) 753-9595 • fax (847) 753-9648
www.dispense-rite.com • sales@dispense-rite.com