

DISPENSE-RITE® SLR-1 SERIES

INSTALLATION & BAFFLE SELECTION INSTRUCTIONS

The cup dispenser is completely assembled but it will require the proper size silicone baffle be inserted once the dispenser has been installed. A full sleeve of cups is recommended for dispenser installation and baffle selection.

If an extra spring was included in the box, you must first decide which spring to use for your application.

To dispense paper or plastic cups in a horizontal mounting position or foam cups in any mounting position use the light compression spring pre-installed inside the cup dispenser -- proceed to BAFFLE SELECTION AND INSTALLATION.

To dispense paper or plastic cups in a vertical or angled mounting position the heavier compression spring will be required. Remove the dispenser's end cap and replace the spring with the one packaged separately with the dispenser (marked with an orange label) -- proceed to BAFFLE SELECTION AND INSTALLATION.

SECTION ONE - CUP DISPENSER INSTALLATION

- 1** Cut a 4-1/2" diameter hole into the desired mounting surface.

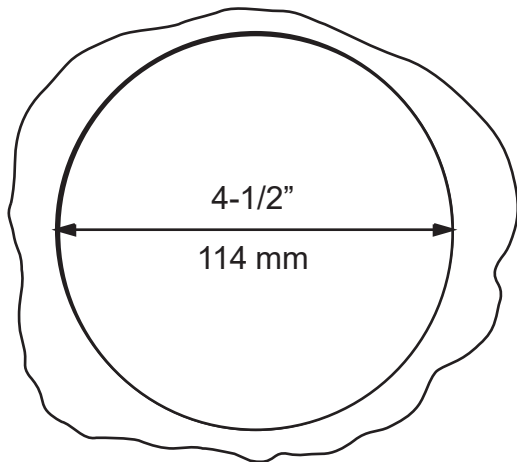

- 3** Insert the dispenser into the mounting hole. Align the "UP" mark to the top in a horizontal or angled application and to the rear in a vertical mounting application.

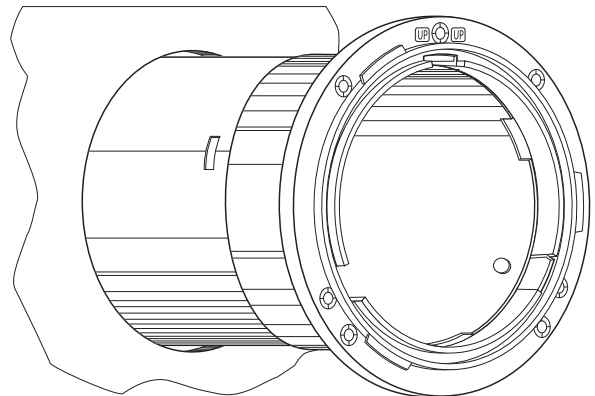

- 2** Rotate the cover ring counterclockwise and remove from the dispenser. Remove the cardboard spacer insert and discard.

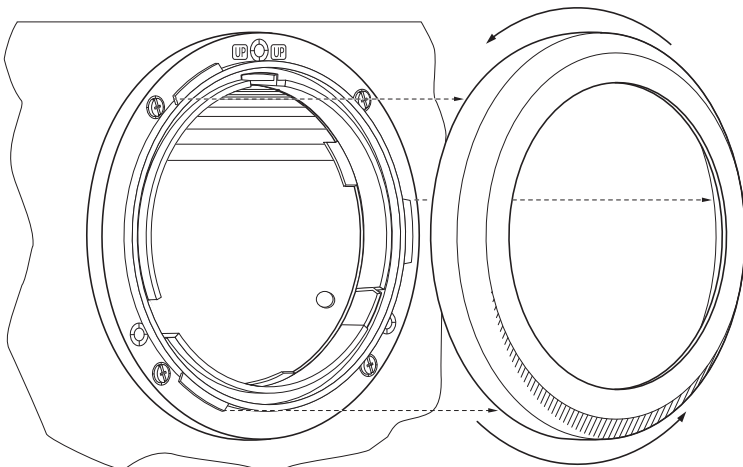

- 4** Drill four 9/64" pilot holes in the locations shown below. Fasten the dispenser with the four #10 screws provided.

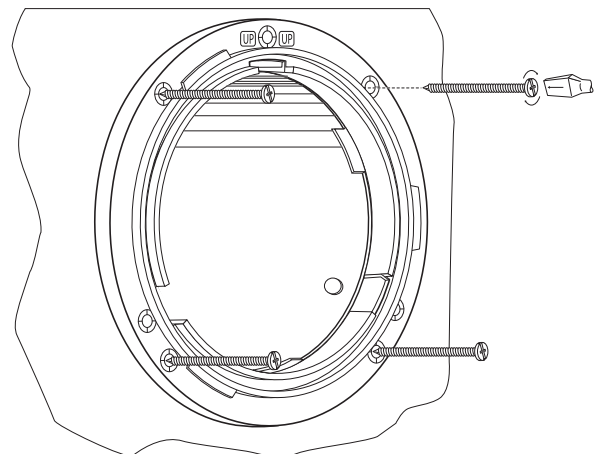

DISPENSE-RITE®

Diversified Metal Products, Inc.

2205 Carlson Drive • Northbrook, IL 60062 • (847) 753-9595 • fax (847) 753-9648

www.dispense-rite.com • sales@dispense-rite.com

SECTION TWO - BAFFLE SELECTION & INSTALLATION

1 If the cup dispenser was shipped with a single silicone baffle pre-installed, no changes are required - proceed to STEP FIVE.

2 If the cup dispenser was packaged with a set of silicone baffles you must determine which is the correct baffle for your particular cup size. Refer to the diagram shown on the right for correct baffle sizing. The appropriate baffle should be selected based on a measurement of the cup's outside rim diameter.

3 Rotate the cover ring counterclockwise and remove from the dispenser. Remove the cardboard spacer insert and discard.

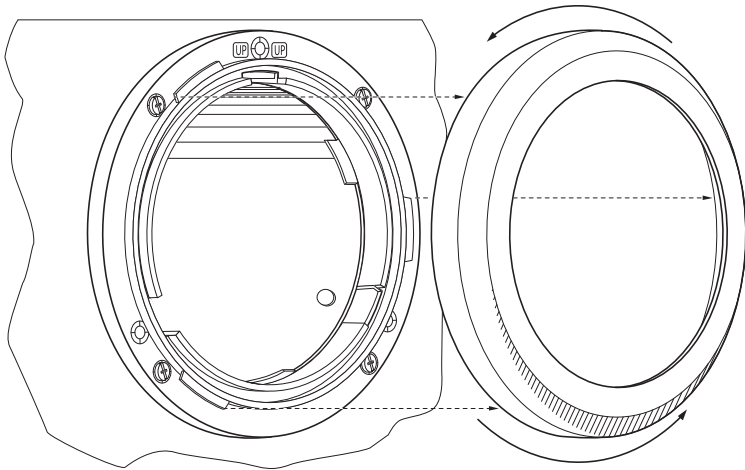

4 Install the appropriate baffle (see step 2) onto the ring by lining up the posts in the ring with the holes in the baffle. Be sure the baffle is completely flush with the underside of the ring and that it is inserted underneath the three retention tabs.

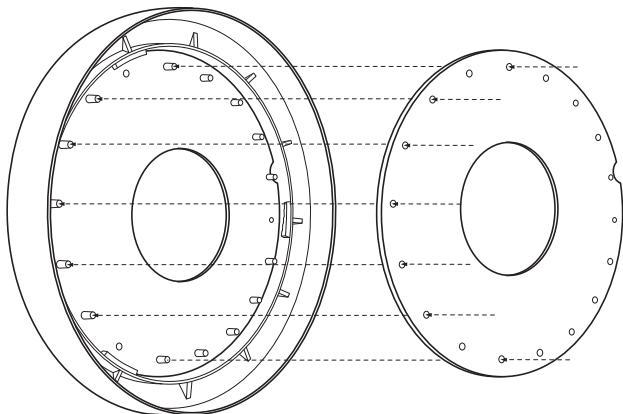

SLR-1 Series Rubber Baffles (select one)

No Notches for Extra Small (XS) Baffle	1 Notch for Small (SM) Baffle
<p>Extra Small Baffle (No notches) Cup Rim Diameters: 2-1/2" - 2 7/8" Approx. Cup Sizes: 4 - 6 oz. Part: SLRB-1XS</p>	<p>Small Baffle (1 notch) Cup Rim Diameters: 3" - 3 1/4" Approx. Cup Sizes: 6 - 12 oz. Part: SLRB-1SM</p>
2 Notches for Medium (MD) Baffle	3 Notches for Large (LG) Baffle
<p>Medium Baffle (2 notches) Cup Rim Diameters: 3 3/8" - 3 5/8" Approx. Cup Sizes: 12 - 20 oz. Part: SLRB-1MD</p>	<p>Large Baffle (3 notches) Cup Rim Diameters: 3 3/4" - 3 7/8" Approx. Cup Sizes: 16 - 24 oz. Part: SLRB-1LG</p>

5 Reinstall the cover ring onto the dispenser and rotate clockwise to secure.

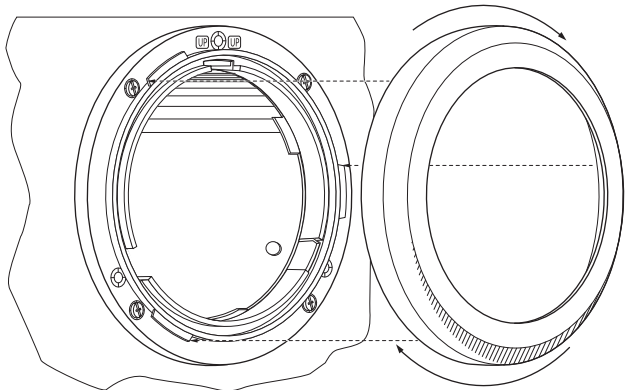

6 Insert a full sleeve of cups into the dispenser to test if the baffle is the proper size for your cups. If you are not satisfied with the dispensing action a baffle change may be required.

Questions? Call (847) 753-9595, ext. 25 8:00 AM - 5:00 PM CST

