

# **DISPENSE-RITE® Model: SLR-2F-CSD**

## **INSTALLATION & BAFFLE SELECTION INSTRUCTIONS**

The cup dispenser is completely assembled but will require the proper size silicone rubber baffle be inserted once the dispenser has been installed. A full sleeve of cups is recommended for dispenser installation and baffle selection.

The SLR-2F-CSD model is a single spring (light) model and is intended for use with paper, plastic or foam cups in horizontal mounting positions. This model may also be used vertically with foam cups. If the dispenser will be used in a vertical or angled position with paper or plastic cups a heavier spring (not included) must be ordered separately.

### **SECTION ONE - CUP DISPENSER INSTALLATION**

- 1** Cut a 5-1/4" diameter hole into the desired mounting surface.

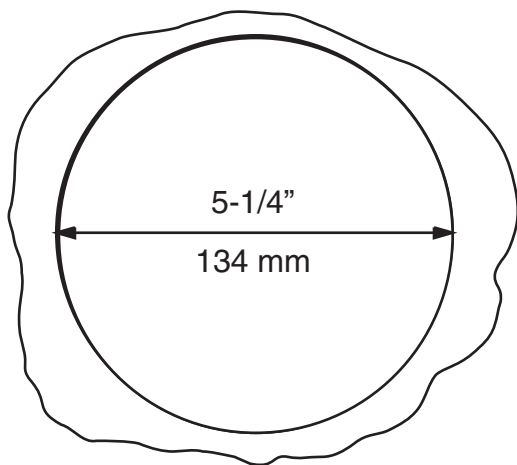

- 3** Insert the dispenser into the mounting hole. Align the "UP" mark to the top in a horizontal or angled application and to the rear in a vertical mounting application.

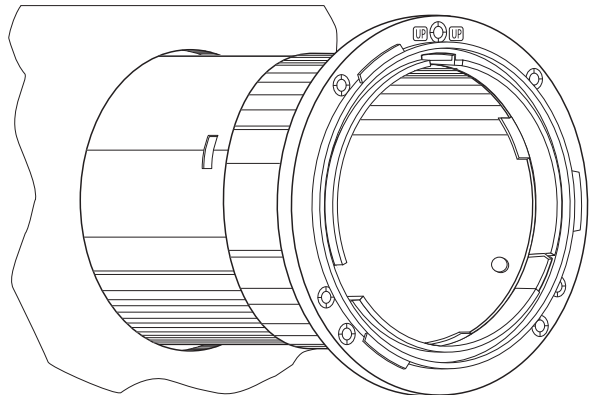

- 2** Rotate the cover ring counterclockwise and remove from the dispenser. Remove the cardboard spacer insert and discard.

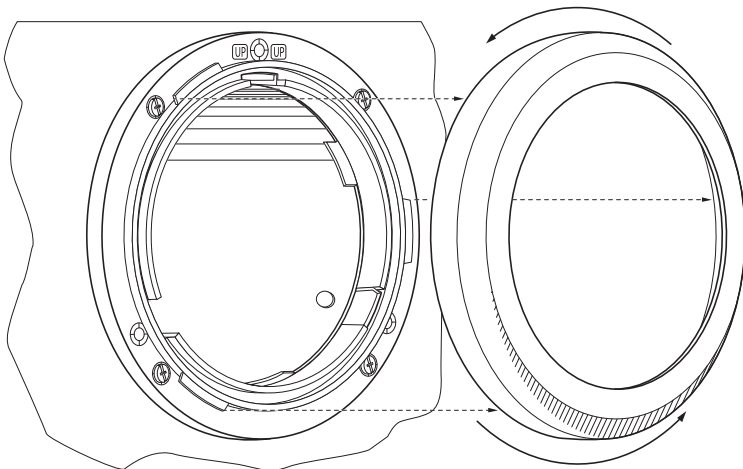

- 4** Drill four 9/64" pilot holes in the locations shown below. Fasten the dispenser with the four #10 screws provided.

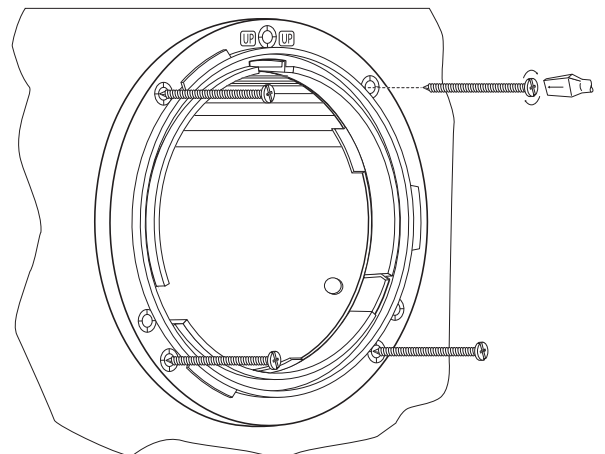

**DISPENSE-RITE®**

**Diversified Metal Products, Inc.**

2205 Carlson Drive • Northbrook, IL 60062 • (847) 753-9595 • fax (847) 753-9648  
www.dispense-rite.com • sales@dispense-rite.com

# SECTION TWO - BAFFLE SELECTION & INSTALLATION

**1** Rotate the cover ring counterclockwise and remove from the dispenser. Remove the cardboard spacer insert and discard. Behind the cardboard spacer you will find a baffle kit with four sizes of silicone rubber inserts.

**4** Reinstall the cover ring onto the dispenser and rotate the ring clockwise to secure.

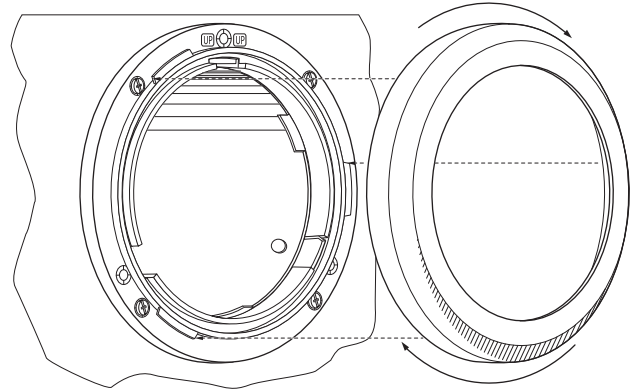
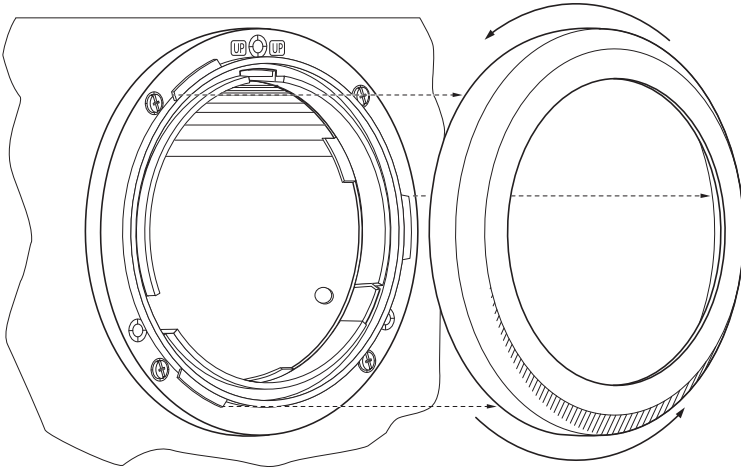

**2** You must determine which is the correct baffle for your particular cup size. Refer to the diagram shown to the right for baffle sizing guidelines. The appropriate baffle should be selected based on a measurement of the cup's outside rim diameter. **For certain foam cups a larger than normal baffle size may be required.**

**5** Insert a full sleeve of cups into the dispenser to test if the baffle is the proper size for your cups. If you are not satisfied with the dispensing action a baffle change may be required.

**3** Install the appropriate baffle onto the cover ring by lining up the posts in the ring with the holes in the baffle. Make sure that the baffle is completely flush with the underside of the ring and that it is inserted underneath the three retention tabs.

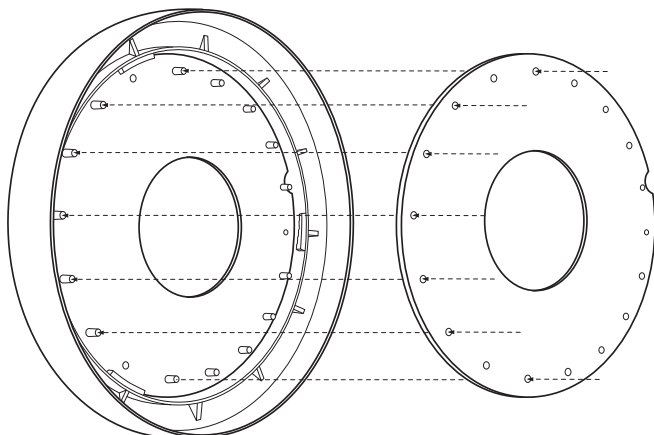

SLR-2F-CSD Baffle Kit (select one)	
<p>2 Notches for Medium (MD) Baffle</p> <p><b>Medium Baffle (2 notches)</b> Cup Rim Diameters: 3 3/8" - 3 3/4" Approx. Cup Sizes: 16 - 24 oz. Part Number: SLRB-2MD</p>	<p>3 Notches for Large (LG) Baffle</p> <p><b>Large Baffle (3 notches)</b> Cup Rim Diameters: 3 3/4" - 4 1/4" Approx. Cup Sizes: 24 - 32 oz. Part Number: SLRB-2LG</p>
<p>4 Notches for Extra Large (XL) Baffle</p> <p><b>Extra Large Baffle (4 notches)</b> Cup Rim Diameters: 4 1/4" - 4 1/2" Approx. Cup Sizes: 32 - 44 oz. Part Number: SLRB-2XL</p>	<p>5 Notches for Extra Large Foam (XL-F) Baffle</p> <p><b>Extra Large Foam Baffle (5 notches)</b> Cup Rim Diameters: 4 3/8" - 4 5/8" Approx. Cup Sizes: 44 oz. Part Number: SLRB-2XL-F</p>

Questions? Call (847) 753-9595, ext. 25 8:00 AM - 5:00 PM CST



Diversified Metal Products, Inc.  
2205 Carlson Drive • Northbrook, IL 60062 • (847) 753-9595 • fax (847) 753-9648  
www.dispense-rite.com • sales@dispense-rite.com